

# POWER PUNCH

A JOINT PROJECT BETWEEN MAEPA & SciFi\_Labs

DATASHEET



# CONTENTS

- Overview
- Features
- Pinouts
- Instructions
- Specifications
- On Board Peripherals
- Dimensions
- Compliance
- Recommended Tips for PCB designs

## Overview

The POWER PUNCH V1 is a petite integrated system designed as surface mount setup around the popular TP4056 IC for Lithium Ion and Lithium Polymer batteries with all the safety features.

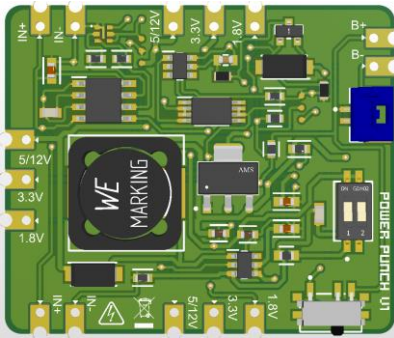

Top Layer

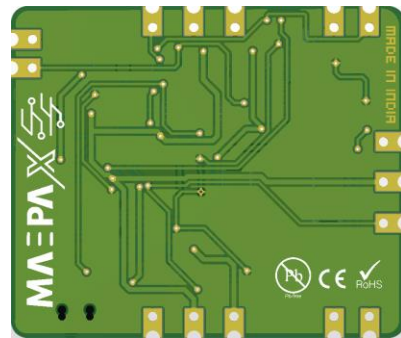

Bottom Layer

POWER PUNCH is Designed and Made in India. The handmade assembly of the board makes it much aesthetic and tidy by ensuring its quality at 100%.

## Features

POWER PUNCH V1 is packed with safe and important features for each type of user with different operations.

- 2 Years of PCB shelf life under the IPC Graded 2 Quality service.
- Complete protection to the battery
- It is capable to deliver up to 2A of output current.
- Most used Voltage outputs.
- Compact size makes it popular to be used in small portable projects.
- Edge connectors further makes it easy to solder on your PCB projects without headers.
- Equipped with On Board 1.25mm JST connector for Lithium Polymer battery.
- RoHS compliant

# Pinouts

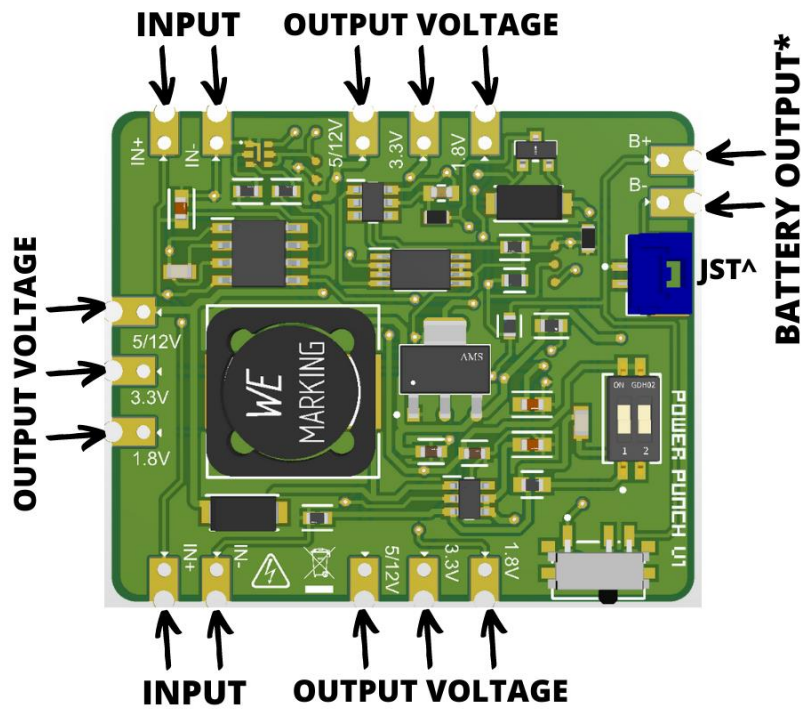

Indications:

\*The Battery output pins are given to connect the Lithium-Ion battery.

^ The JST connector is a provision given to connect the Lithium Polymer battery directly with a Plug in – Plug out interface.

# INSTRUCTIONS

These are some important handling instructions to the user before using the POWER PUNCH V1.

1. The Bi-Switch setup has a unique purpose.
  - When Switch 1 is up and 2 is down, the output is 12V
  - When Switch 2 is down and 2 is up, the output is 5V
2. To avoid complications, the GND pins on the board are IN- and B-
3. The Slide Switch in ON position discharges the battery and in OFF position Charges the battery.
4. Never try to replace the parts on your knowledge, if there is any case for repair, the user can reach us and get the desired knowledge to perform the task.

## Specifications

Protection	Over Charge, Over Discharge and Short Circuit protection
Output Voltage	1.8V, 3.3V, 5V, 12V
Input Voltage	3V ~ 5V
Output Current	2A ~ 3A
Variant	Black + ENIG
LED Indication	Red, Green, Blue
Weight	50g
Dimensions	35.69mm x 42.42mm x 1.6mm

As per the tests done in various conditions, the following readings has been recorded which stand near to the theoretical values.

Theoretical	Measured
1.8V	1.69V
3.3V	3.29V
5V	5.02V
12V	12.45V
1.5A	2.01A

## Onboard Peripheral

1. The POWER PUNCH V1 is built on a TP4056 system for 1A Lithium Ion or Lithium Polymer cell.
2. The Board is equipped with a Slide Switch that helps the user choose if the battery needs to be charged or not.
3. The 5V and 12V can be switched at a time.
4. The LED on board helps to know the state of the POWER PUNCH.
  - If, the LED turns “RED”, It means the battery is in charging.
  - If the LED turns “GREEN”, It means the battery is fully charged.
  - If the LED turns “BLUE”, It means the output voltage is 3.3V.



# DIMENSIONS

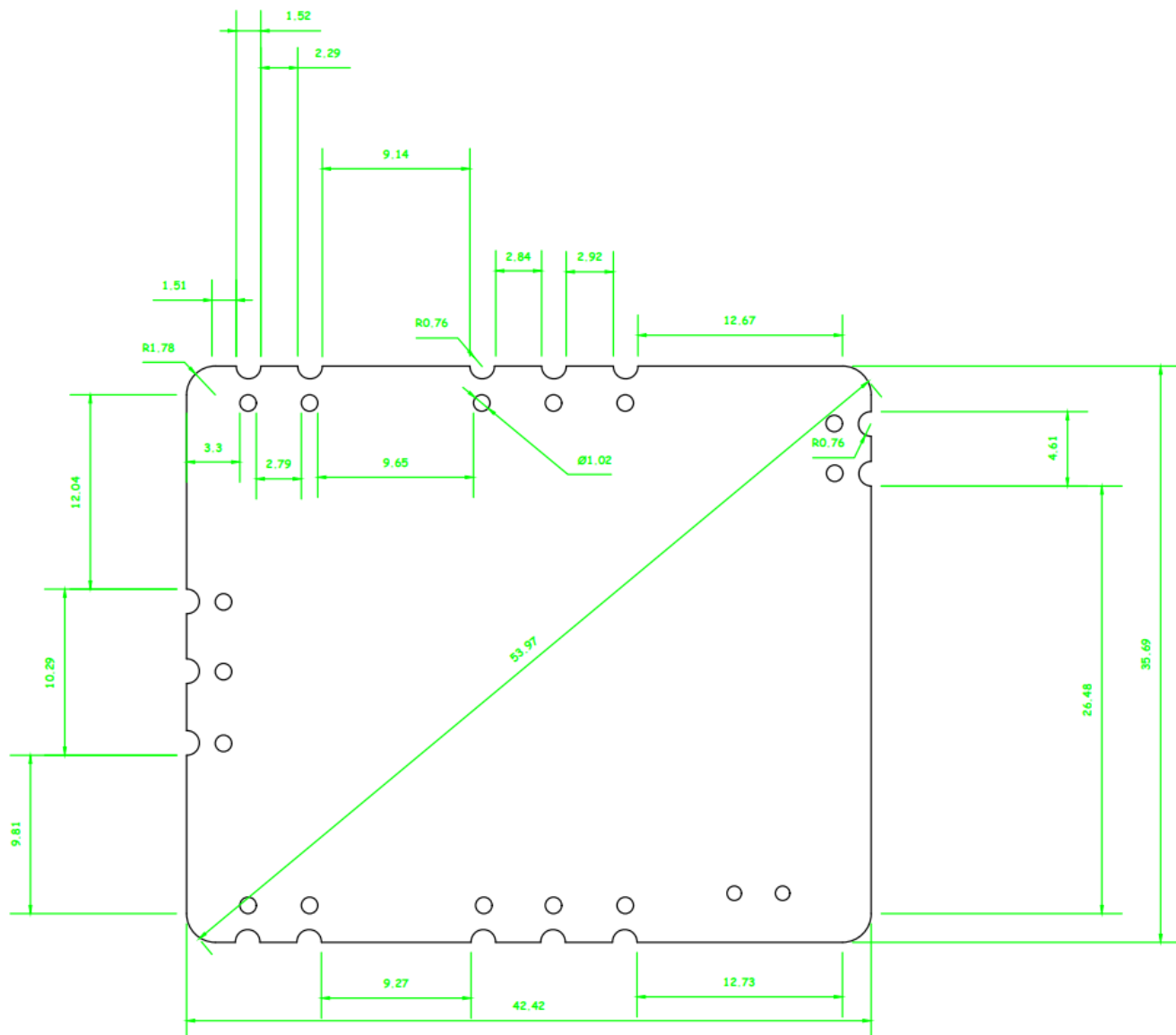

All dimensions are in millimetres (mm) only.

## RECOMMENDED PCB TIPS

For POWER PUNCH V1, the following are the recommended PCB Designing guidelines.

1. Prefer a 2-layer PCB when working with POWER PUNCH, and give most of the tracks on the layer opposite to the layer where POWER PUNCH V1 is planned.
2. GND the copper layers with GND connections of the POWER PUNCH V1 i.e., IN- and B- pads.
3. For voltage rails, a track thickness of 0.5mm is recommended.
4. For protection the board, we recommend to use a couple of resistors or TVS diodes (20V minimum) connected between the input pads.
5. It is recommended that you have the connectivity tests of your PCB before soldering the POWER PUNCH V1 on the board.

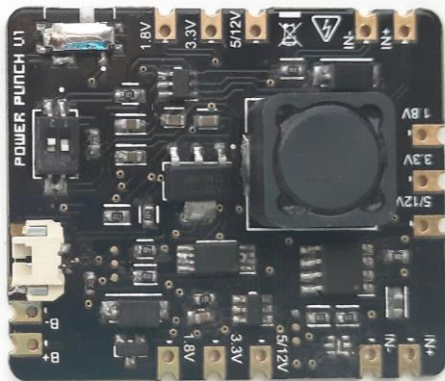

## **Compliance and Safe Disposal**

The POWER PUNCH V1 is RoHS compliant under the EU directive.

We believe in Healthy environment for all, and respect the resources available to us from the nature.

As an additional compliant policy, the POWER PUNCH V1 can be sent back to us for recycling, repairing or safety disposal in the environment with proper and adequate process by controlled recycling services.

Reach us out today on social media or support email.